



# Shelving and End Panels

## Request for Proposal

**Issued:**

Tuesday, April 16, 2024

**Submission Deadline:**

Monday, May 13, 2024, 12:00pm

**Deliver to:**

Amanda Wiley  
Division Manager, Southwest Library  
Kitchener Public Library  
85 Queen St. N., Kitchener, ON  
519-743-0271 ext. 348  
[awiley@kpl.org](mailto:awiley@kpl.org)

## Definitions

“**Bidder**” means a contractor that the KPL has invited, and/or a contractor that requested to be part of the process to submit a response to its Request for Proposal;

“**Bidders**” means every Bidder.

“**Contract**” or “**Agreement**” means the document executed by the KPL and the Contractor containing the terms and conditions governing the procurement, including any Schedules, Exhibits and Appendices as it or they may be amended or supplemented from time to time.

“**Contractor**” or “**Proponent**” or a pronoun in place thereof, means the successful Bidder selected by the KPL, and upon execution of an Agreement and/or acceptance of a Purchase Order; shall complete the Work as per the terms and conditions agreed upon.

“**Defective, Deficiency or Fault**” and “**Defects, Deficiencies or Faults**” means any one or a combination of the following items or other items of a substantially similar nature, and will be deemed to exist when actually discovered or when they should have been apparent to a person in the Contractor’s position after reasonable inspection and testing:

- a) Items of Work (including any work by any Subcontractor) that are not provided in a workmanlike manner and in accordance with the standards and/or specifications identified in the Agreement;
- b) Items of Work (including any work by any Subcontractor) that are not (i) new and of good quality and free from improper workmanship and defects in accordance with the standards and/or specifications identified in the Agreement, or (ii) free from errors and omissions in design or engineering in light of good procurement, manufacturing or construction standards;
- c) In general, items of Work (including any work by any Subcontractor) that do not conform to the specifications and/or requirements of the Agreement, or would materially and adversely affect the ability of the System and/or any material part thereof to meet any performance criteria specified on a consistent and reliable basis, or would materially and adversely affect the continuous operation or expectations of the System or any material part thereof.

“**Including**” means including without limitation, and “**includes**” means includes without limitation.

“**KPL**” means Kitchener Public Library

“**KPL Representative**” means the member of staff responsible for operating, administering and/or performing minor maintenance work on the system.

“**Library**” means Kitchener Public Library

**“Occupational Health & Safety Act”** means the Occupational Health and Safety Act R.S.O. 1990, c. O.1 as amended, which administers, manages and regulates occupational health and safety practices in the Province of Ontario through the Ministry of Labour.

**“Proposal”** means the Bidder’s response to the KPL’s Request for Proposal;  
**“Proposals”** means every response received as a result of the procurement process.

**“Request for Proposal” (RFP)** means the Request for Proposal document issued by KPL and provided to Bidders.

**“Work”** means the work undertaken by the Contractor and its Subcontractors (if any), pursuant to the provisions of the Agreement. Work includes all labour, consulting, materials, equipment, services and any other items used by the Contractor or its Subcontractors to complete the project

## Introduction

Kitchener Public Library (KPL) is seeking proposals from a qualified contractor to supply, deliver, and install shelving and custom end panels for a new library branch located in Southwest Kitchener.

## Background

Kitchener Public Library currently has five locations: a Central Library in downtown Kitchener and four community libraries, which together serve a growing city of 261,600.

The Southwest Library will be the sixth branch in the KPL system. It is currently under construction. This library is a standalone facility, approximately 14,000 sq. ft. in size. It is a unique space, which includes a teaching kitchen, recording studio, digital media lab, and outdoor area for programming and gathering.

The Southwest Library will be a NetZero building. This means that it will be a high energy-efficient build that produces 100% carbon-free renewable energy to offset the annual carbon emissions from the building materials and operations. This will be one of the first public libraries with this designation in Canada.

The discovery of Indigenous artifacts and a First Nation Village near the site informs the responsibility to work with Indigenous partners to ensure that land, building and programming reflect the shared relationships and responsibility to the land.

## Scope of Work

This RFP is seeing a contractor for library shelving and end panels and configurations to be installed in the Southwest Community Library.

The Southwest Library is currently being built with an anticipated building occupancy of January 2025. Occupancy timelines are subject to change and will be confirmed by October 2024.

It is the responsibility of the successful vendor to confirm measurements and specifications before manufacturing the shelving and end panels.

The Proponent will perform all services and provide all necessary labour, supervision, trucking, equipment, storage, materials, hoisting equipment, permits, insurance bonds, miscellaneous small tools, rigging, cleaning and protective materials and all other items necessary to complete the project.

KPL staff will be in the building and contractors will be on site during the installation process.

All shelving and end panels will be placed according to the plan developed in consultation with library staff. Library staff shall have final authority in directing and supervising elements of work which may affect the proper placement of shelving and end panels.

## Timeline for Major Milestones

RFP issued: Tuesday, April 16, 2024

Deadline for questions: Thursday, April 25, 2024

Deadline for RFP submissions: Monday, May 13, 2024

Award of contract: Week of May 20, 2024

Planning and coordination with Library staff: May-July 2024

Building Occupancy: anticipated January 2025, date to be confirmed

Facility Opening: Q1 2025

## Contractor's Responsibilities

The Contractor has full responsibility for properly estimating the cost and challenges of performing the services required herein and will not be excused from this responsibility for failure to investigate the conditions or become acquainted with all information concerning the services to be performed.

Responsibilities of the successful Contractor will include but not be limited to providing all supervision, personnel, labour, materials, supplies, storage, FOB delivery to KPL and equipment to perform the services described in this RFP in a professional and timely manner. The Contractor may not use Library's personnel, materials, supplies, or equipment except as provided specifically in this RFP, or as provided in subsequent agreements with the Library which are mutually satisfactory to both parties. The Contractor must have a Project Supervisor assigned and present during the installation, not permit any temporary halts in the performance of the Project, and make no assignment of Project staff to another job until the Project is complete unless with the agreement of the Library.

The Contractor, at their own expense, will obtain and maintain all necessary permits, franchises, licences, or other certification required to carry out the operations, handling and other services to be performed under this contract.

The Contractor will comply with all local, provincial, and federal safety rules, regulations or laws. The Contractor will erect temporary barriers and other protection necessary to protect persons and property from injury or damages during all stages of work.

The Contractor's Project Supervisor will supervise and administer the actual installation of shelving in cooperation with the following authorized Library personnel:

Angela Riddell, Director, Business Services & Infrastructure

Penny-Lynn Fielding, Deputy CEO

Amanda Wiley, Division Manager, Southwest Library

The Contractor will include adequate time for planning sessions with Library staff during the period between the contract award and the actual installation. Compensation for any travel, meals, lodging or incidentals related to attendance in these sessions will be included in the proposal cost.

## **Protection of Property and Facilities**

The Contractor shall take the necessary precautions to prevent damage or injury to existing property at the site. Any damage or injury caused by the Contractor shall be repaired at the Contractor's expense. The Contractor and Library staff shall inspect the work site and jointly note existing conditions prior to starting the work. The work site shall be jointly inspected after all work has been completed in that area and Contractor caused damages, if any, will be documented

The Contractor will protect the walls, floors, furniture, artwork, equipment, fixtures and other areas or materials as designated by the Library. The Contractor will protect corners, corridors, and floors with protective coverings or padding.

The Contractor will at all times keep the premises free of waste materials caused by the Contractor's work or employees including shipping and packaging materials, food wrappers, cans or food waste which will be removed or disposed of daily. Eating and drinking will be permitted only in areas designated by the Library.

## **Project Coordination**

The Contractor will provide a timetable and create an installation plan. The Contractor will be responsible for providing Library staff with guidelines and assistance during planning stages of the installation and will participate in planning meetings as necessary to effectively communicate for the planning, coordination and implementation of the installation. The Contractor will provide clear and concise communication to all who are involved in the installation.

Upon completion of the installation of the shelving and end panels and before acceptance and final payment the Contractor will:

1. Remove from the site and dispose to a location approved by the Library, all equipment, containers, supplies, and debris which the Contractor brought to the site. Such removal and disposal will be at the Contractor's expense. This will include clean up following completion of the project.
2. Repair or make arrangements with the Library for repair of any damage caused by the Contractor to the building or its contents.
3. Should the Contractor fail to fulfill conditions of this section, the Library may after written notice complete these tasks and deduct the costs from the final payment to the Contractor.
4. Final inspection and correction of deficiencies will be completed within seventy-two (72) hours after the Contractor has notified Library Representatives that the installation has been completed, including clean-up.

## Library's Responsibilities

The general responsibility of the Library is to aid and assist the Contractor in facilitating the work to be performed under the contract. Library staff will be involved in planning preparation, and supervision of the installation, including, for example:

1. Protection and care of library facilities during the work
2. Coordination between shelving contractor and general contractor overseeing library construction
3. The placement of shelving units and end panels
4. The installation sequence, and scheduling, etc.

Specific responsibilities are limited to the following:

1. Library staff will be responsible for the preparation of specific floor layouts and designation of shelving locations.
2. The Library will ensure adequate staff for answering questions regarding installation and for providing other advice and assistance to the Contractor as may be needed.
3. The Library will assume responsibility for providing the necessary access to and within the building.
4. Authorized representatives of the Library will be responsible for coordinating contact between the Contractor and other departments and functions of the Library as may be necessary.
5. The library is responsible for coordinating the activities and tasks of other agents of the Library.
6. The Contractor may not use any Library equipment or personnel except s provided in these specifications.

## Proposal Submission Format

The proposal should follow the format outlined in this RFP.

Complete the Pricing Submission Form and return all materials via email to [amanda.wiley@kpl.org](mailto:amanda.wiley@kpl.org)

Addressed to:

Kitchener Public Library

Attn: Amanda Wiley, Division Manager, Southwest Library

85 Queen Street North

Kitchener, ON N2H 2H1

Proposals must be received no later than 12pm, Local Time, on Monday May 13, 2024.

Proposals MUST be signed by an authorized signing officer of the Proponent Company.

In order to facilitate the evaluation of the proposals, the following presentation order is requested:

Introduction  
Understanding of the Project  
Methodology Used for the Project  
Management Plan for the Project  
Relative Experience and Qualifications  
References  
Pricing Submission Form

## **Responses must include the following**

### **Identification of Staff**

Describe the system by which the Proponent's staff will be identified while on Library premises.

### **Project Planning and Pre-Installation Meetings**

Provide an estimate of the number, schedule, participants and anticipated content of planning and pre-installation meetings involving staff of Proponent, Library, and others.

### **Proposed Work Plan and Timeline**

Provide a detailed proposed work plan and time line for completing the project. Describe the proposed general plan of action in chronological steps including placement of order, delivery and installation required to meet the project schedule.

### **Experience and Capacity**

Describe the firm's background and experience that demonstrates the ability to provide the required services. Indicate whether any subcontractors are required to provide the services specified in the RFP.

### **Contractor's Project Supervisor**

Provide name, resume, references, past experiences in installations of this kind or scope, and contact information for the person designated to act as the Contractor's Project Supervisor.

### **Contractor's Staff**

Describe how the project will be staffed and work teams organized, include chain-of-commands, use of sub-contractors, and number of supervisory personnel on site, quantity and make-up of work teams.



### **Installation**

Identify whether the installation will be performed by the Contractor's staff or by sub-contractors the name and address of each must be provided. The Contractor shall not be allowed to substitute other sub-contractors in place of those named in the proposal without written approval from KPL.

### **Installation Experience**

List all experience in the previous calendar year with installations of similar size and scope. Include a description of the approximate quantity of shelving units and end panels involved. Outline any significant problems encountered during the installations, and the solutions provided.

### **References**

Provide a minimum of three references, including the names and contact information (address, telephone number, email address) of person(s) qualified to comment on the performance of your firm.

## **Addendum**

No oral interpretations shall be made to a Bidder as to the meaning of the contract documents, or be effective to modify any of the provisions of the contract documents.

Requests for additional information or interpretation of RFP documents regarding terms, conditions, specifications, and performance requirements shall be submitted in writing to:

Amanda Wiley, Division Manager, Southwest Library  
[amanda.wiley@kpl.org](mailto:amanda.wiley@kpl.org)

Questions will be answered in writing in the form of addenda to the RFP and copies will be furnished to all proponents by electronic mail. The Library will be the sole determinant of whether any revision or addenda should be issued as a result of any questions or other matters, and will extend the proposal deadline if such information significantly alters this solicitation or makes compliance with the original due date impractical.

All requests for interpretation must be received no later than 12:00pm on Thursday, April 25, 2024 in writing (via email). Interpretation by the Library will be issued to proponents in the form of an addendum to the RFP and will be available no later than 5:00pm on Monday April 29.

Addenda will sent by electronic mail to each proponent to whom the RFP has been issued. All such addenda shall become part of the RFP response and each proponent shall be bound by such addenda.

The successful proponent's proposal and supporting information, along with this RFP and other written communication, will become part of the contract between the Kitchener Public Library and the successful proponent.

## Informal or Unbalanced Proposals

Proposals which are incomplete, conditional, illegible, obscure or qualified in any way, or that contain additions not called for, erasures, alterations or irregularities of any kind, shall be rejected as informal.

Proposals that contain prices which appear to be so unbalanced as likely to affect adversely the interests of KPL may be rejected.

Whenever a proposal in the amount proposed for an item does not agree with the extension of the estimated quantity and the proposed unit price, the unit price shall govern and the amount shall be corrected accordingly.

## Omissions and Discrepancies

Notify, in writing, by e-mail [amanda.wiley@kpl.org](mailto:amanda.wiley@kpl.org) at once of discrepancies found in, or omissions from, the specifications or other documentation, or if in doubt as to their meaning. The KPL may issue written addenda in the form of e-mail to all Bidders.

**KPL shall not be responsible for any verbal instructions.**

## Proposal Acceptance Period

It is understood that, in submitting a Proposal, each Bidder agrees that their Proposal may be subject to acceptance up to thirty (30) working days after closing date for proposals.

## Acceptance or Rejection of Proposals

KPL reserves the right to reject any or all proposals and the lowest or any proposal will not necessarily be accepted.

KPL reserves the right to accept any proposal that is considered best for the interests of KPL.

KPL shall not be responsible for any liabilities, cost, expenses, loss or damage incurred, sustained or suffered by any Bidder by reason of the acceptance or non-acceptance, by KPL, of any proposal or by reason of any delay in the acceptance of a proposal save as provided in the contract.

No proposal shall be accepted from any person or corporation who, or which, has a claim or has instituted a legal proceeding against KPL or against whom KPL has a claim or has instituted a legal proceeding with respect to any previous contract, without the prior approval of Kitchener Public Library.

The Bidder acknowledges and agrees that nothing contained herein, in the proposal documents or elsewhere, no act done or expense incurred by it in the preparation and submission of this proposal, no trade or industry custom or practice, and no representation or assurance that may have been made or given to it by or on behalf of KPL, shall in any manner legally bind KPL, in any circumstances, to accept a proposal, the

lowest proposal, only a proposal submitted in compliance with the requirements of the proposal documents, or any proposal at all. The Bidder further acknowledges and agrees that KPL shall have complete and unrestricted liberty in this regard and may reject any or all proposals, or may accept any proposal in whatever manner, at whatever proposed price, on whatever terms and for whatever reasons as KPL, in their absolute discretion, consider to be in its best interests, all without liability or obligation of any kind to the Bidder.

## Workplace Safety and Insurance Board

The Contractor shall at all times pay, or cause to be paid, any assessment or compensation required to be paid pursuant to the Workplace Safety and Insurance Act and upon failure to do so, KPL may pay such assessment or compensation to the Workplace Safety and Insurance Board, and the Contractor shall forthwith reimburse the KPL. KPL may, at their option, deduct such expenses from any monies owed to the Contractor. The Contractor shall, prior to issuance of purchase orders by KPL, provide a certificate of good standing from the Workplace Safety and Insurance Board, and KPL shall during the term of the contract, require ongoing updated certificates.

## Insurance Provisions (Standard)

The Contractor shall insure its undertaking, business and equipment so as to protect and indemnify and save harmless Kitchener Public Library from any and all costs, claims, demands, damages, fines, suits, actions, and judgments made, brought or recovered against Kitchener Public Library, for any bodily injury, death or property damage caused by or resulting from the operation and business carried on by the Contractor under this Agreement.

- a) **General Liability Insurance:** The Contractor shall maintain liability insurance acceptable to Kitchener Public Library throughout the term of this Agreement. Coverage shall consist of a comprehensive policy of public liability and property damage insurance in an amount of not less than \$2,000,000 per occurrence. Such insurance shall name the Corporation of The Kitchener Public Library of Kitchener as an additional insured thereunder and shall be endorsed to include a Cross-Liability Endorsement with a Severability of Interests Clause, Premises and Operations Liability, Blanket Contractual Liability, Products / Completed Operations Liability, Personal Injury Liability and Non-Owned Automobile Liability.
- b) **Automobile Liability Insurance:** The Contractor shall maintain automobile liability insurance on all Owned and Leased Automobiles to a limit of \$2,000,000 throughout the term of this Agreement.
- c) **Provisions:** Prior to issuance of a Purchase Order and prior to the commencement of any work, the successful Contractor shall forward a Certificate of Insurance evidencing this insurance with the executed Agreement. The Certificate shall state that coverage will not be suspended, voided, cancelled, reduced in coverage or in limits except after thirty (30) days prior written notice by certified mail to Kitchener Public Library. It is also understood and agreed that in the event of a claim any deductible or self-insured retention under this policy of insurance shall be the sole

responsibility of the Contractor and that this coverage shall be primary insurance as respects Kitchener Public Library. Any insurance or self-insurance maintained by Kitchener Public Library shall be considered excess of the Contractor's insurance and shall not contribute with it.

Kitchener Public Library reserves the right to modify the insurance requirements as deemed suitable.

## **Occupational Health and Safety**

The Contractor shall at all times ensure work complies with the most recent edition of the Occupational Health and Safety Act and all applicable regulations, codes, standards and guidelines as amended, and shall be responsible for and take every precaution reasonable in the circumstances for the protection of all workers associated with the work being performed. The successful Proponent shall indemnify and save harmless the Library, its officers, employees, servants and agents from any liability incurred as a result of the Proponent's negligence or any latent or obvious violation of the Occupational Health and Safety Act.

## **Laws and Regulations**

The Bidders are assumed to have made themselves familiar with and will abide by all Federal, Provincial, Municipal and Local Laws, rules and regulations which in any way affect the work, and no plea of misunderstanding will be considered on account of ignorance thereof. If the Bidder shall discover any provisions in the drawings, specifications or contract that are contrary to or inconsistent with any law, rule or regulation, they shall at once report it to the KPL's Representative, in writing.

## **Laws**

It is agreed that the goods supplied shall comply with all Federal, Provincial and other laws applying thereto.

## **General Conditions**

### **General**

This proposal, including these terms and conditions, forms the entire contract between the parties, and no variations thereof, irrespective of the wording of the Bidder's acceptance will be effective unless specifically agreed to in writing.

### **Quality of Work and Materials**

The quality of materials shall be new and first class in every respect and the quality of work is to be to accepted trade practices.

## Contractor's Insolvency

The purchase may be terminated, at each KPL option, effective upon written notice to the Contractor in the event that: Contractor files for bankruptcy, becomes insolvent, makes an assignment for the benefit of creditors, or has a receiver appointed, or any proceeding is demanded for, by or against the Contractor under any provision of the Federal Bankruptcy Act, as amended or any applicable Provincial Law.

## Contractor's Default

Upon any default of the Contractor, KPL may reduce or may cancel the contract(s) in the event that any delivery or deliveries affected are not made at the time specified in this Proposal.

## Contract

None of the terms and conditions contained in a bidders standard or a bidders general sale agreement, and none of the bidders supplemental information and written amendments to the intent and tone of the RFP document shall be binding or have any effect on KPL unless explicitly agreed to in writing by KPL and set forth as an amendment. The Contract shall be governed and interpreted as detailed here and also in accordance with the laws of the Province of Ontario.

## Pricing

Firm prices in Canadian dollars are being requested and the term for these should be noted on the pricing submission form. If the Bidder is unable to bid on this basis, please detail the pricing policy and include it with the proposal. All prices shall include applicable customs duty, excise tax, freight, insurance, storage (including storage requirements due to delays in flooring installation), labour and all other charges of every kind attributable to the work and represent the actual cost to KPL. If the extended value is inconsistent with the unit price, the unit price shall prevail, and the total price will be corrected accordingly.

## Proposal Submission

A vendor may withdraw or qualify a bid at any time prior to the official closing time by submitting a letter bearing an authorized signature on letterhead. Submissions are irrevocable after the official closing time.

## Cost of Proposal

This RFP does not under any circumstances commit KPL to pay any costs incurred by any Bidder in the preparation and submission of a Proposal. The Bidder is responsible for all costs associated with its involvement in the process.

## **Incomplete Proposals**

Partial or incomplete proposals shall not be given the same consideration that complete or near complete proposals will receive.

## **Qualified Proposals**

Bidders are cautioned against qualifying their proposals in any manner whatsoever, as this may result in their proposal being rejected. However, descriptive literature may be included, as long as its sole purpose is only to amplify a response that has been requested in the proposal. Should you wish to elaborate on any aspect, do so separately on company letterhead.

## **Patents**

Bidders shall hold and save KPL, their officers, agents and users of its products, harmless from liability of any kind for or on account of the use, sale or lease of any patented or unpatented invention, article or appliance furnished or used hereunder.

## **Warranty**

Bidders shall provide a full statement of the warranty. The warranty should clearly describe the terms under which the Bidder accepts responsibility for the cost to repair defects caused by faulty design, quality of work or material and for what period of time after installation.

## **Force Majeure**

If the Contractor is delayed in delivery by labour disputes, strikes, lock-outs, fire, or by any cause of any kind whatsoever beyond the contractor's control then the time of delivery shall be extended for a period of time equal to the time lost due to such delays, at no cost penalty to KPL.

No such delivery time extension shall be made for delays unless written notice of same is given to KPL within seven (7) days of its commencement. Where it is the case of a continuing cause of delay only one claim shall be necessary.

## **Assignment**

Neither this Proposal nor the right to receive payment hereunder may be assigned or transferred without the prior express written consent of KPL and any attempted assignment shall be void and of no force or effect against KPL.

## **Evaluation**

The ability to conduct a thorough evaluation of a proposal depends on submissions that are well-ordered, detailed and concise. Clarity of language and adequate documentation is essential.

Proposal evaluation criteria will include the qualifications of the proponent and any of the proponent's potential subcontractors, the nature of the proposal plan, terms and conditions proposed by the proponent, and total proposed cost. The proponent and any of the proponent's potential Subcontractors must demonstrate adequate and appropriate ability, skill, capacity, responsibility, expertise, previous work record and experience, financial standing, overall quality and effectiveness of work, and all necessary equipment and materials to promptly and efficiently accomplish the scope of the required services.

The Library reserves the right to select the proposal that best meets the Library's requirements. Cost will be a primary consideration, but proposals will be evaluated on all criteria contained in this RFP. The lowest or any other bid will not necessarily be accepted and the Library reserves the right to accept or reject all or any part of a submission contingent upon the terms of the specific proposal request.

Proposal evaluation criteria will include:

1. Technical competence as evidenced by:
  - a. Professional qualifications of the firm and sub-contractors
  - b. Past performance of the firm and sub-contractors as verified by the references of previous clients
  - c. Demonstrated experience in installation of shelving projects of similar size
2. Respondent's fulfillment of mandatory requirements
3. Cost of proposal and associated value for money
4. Proposed schedule and length of time for project completion
5. Demonstrated understanding of an ability to meet scope of project

## Evaluation Committee

The evaluation committee will be comprised of Kitchener Public Library staff. The committee will review and evaluate all submissions.

## Confidentiality

All information regarding technical aspects of the proposal, which in the Bidder's opinion, is of a proprietary or confidential nature, should be clearly marked "Confidential" at each relevant item or page. All information marked confidential will be held in strict confidence and shall not be revealed to another party without the Bidder's consent except as may be required by any applicable Law. Similarly, information about KPL obtained by the Bidder and declared confidential by KPL shall not be disclosed unless authorized by KPL. It is agreed that these reciprocal obligations of confidentiality will survive the termination of any contract that may arise between KPL and a successful Bidder.

## Award Process

Pursuant to a recommendation being approved, a purchase order/contract will be issued to the successful proponent by Kitchener Public Library.

The Terms of Reference and Conditions of the RFP document will form a part of the Purchase Order.

All proponents will be notified when the evaluation process is complete.

## **Kitchener Public Library's Rights**

Kitchener Public Library reserves the right to terminate the process described in this Request for Proposal at any time, including before the closing date, for any reason whatsoever and will not be responsible for any costs incurred by vendors in the preparation and submission of their responses to this Request for Proposal.

All costs and expenses incurred by Proponents relating to a Proposal and any negotiations with the Library will be borne by the Proponents. The Library is not liable to pay such costs or expenses or to reimburse or compensate Proponents under any circumstances, including the rejection of any or all Proposals.

The Library shall not be responsible for any liabilities, costs, expenses, loss or damage incurred, sustained or suffered by any proponent, prior or subsequent to, or by reason of the acceptance or the non-acceptance by the Library of any proposal, or by reason of any delay in the acceptance of this proposal.

The Library will not accept responsibility for any delays or costs associated with any reviews or its approval process.

The Library expressly reserves the right to terminate the RFP process before or after negotiations and to terminate any next steps flowing from it.

The Library does not accept responsibility for any information or any errors or omissions which may be contained in this RFP or the schedules, data, materials or documents disclosed or otherwise provided to the Proponent in this RFP or from time to time pursuant to this RFP. The Library makes no representation or warranty, either express or implied, in fact or in law, with respect to the accuracy or completeness of this RFP or such schedules, data, materials or documents, and the Library shall not be responsible for any action, cost, loss or liability whatsoever arising from the Proponent's reliance or use of this RFP or any other technical or historical schedules, data, materials or documents provided by the Library. The Proponent is responsible for obtaining its own independent financial, legal, accounting, engineering and technical service advice with respect to any information included in the RFP or in any schedules, data, materials or documents provided by or required from the Library or from time to time pursuant to this RFP.

Proponents shall not issue news releases or other public announcements pertaining to details of a proposal or the selection process without the prior written approval of the Library.



This RFP process is designed to allow the Library to select one or more proponents with whom it will attempt to negotiate an arrangement responsive to the Library's needs. Selection as a proponent with whom the Library will negotiate does not guarantee that the Library will conclude an arrangement with the proponent. The Library expressly reserves the right to terminate the RFP process before a proponent is selected, to terminate negotiations with a proponent or to determine that the Library's needs can be met, or have been met, in a different manner.

Kitchener Public Library reserves the right to cancel the resulting contract in the event that the successful proponent fails to perform in accordance with the Terms, Conditions, Specifications and Time Schedules of the contract. This will be in the sole opinion of Kitchener Public Library. In this case only prorated payments pertaining to completed and acceptable work will be remitted.

The copyright for respective purchased concepts and/or materials will become the property of Kitchener Public Library unless otherwise mutually agreed upon by the successful proponent and the Library.

If the respondent intends to use subcontractors, the bidder must identify in the proposal the names of the subcontractors and the portions of the work the subcontractors will perform.

The Library's project director must approve any change of sub-contractor or project team members named in the proposal, in advance and in writing. Personnel changes that are not approved by Kitchener Public Library may be grounds for the Library to terminate the contract.

## Library Shelving Requirements – General

The Southwest Community Library requires a shelving system that provides the maximum number of options for storing and displaying library materials. The shelving system must meet the following general requirements:

- High quality gauge of steel – specify gauge in proposal. All gauges in US Standard.
- Closed shelving system including kick plates and dustcovers (steel canopy tops). Steel canopy tops to be affixed to bays using screws.
- Custom end panels for double sided shelving.
- Steel end panels for single sided shelving, colour to match shelving colour. Sized to match dimensions of shelving for flush exposure.
- Custom end panels with animal spaces for specific children's shelving (either made in house or sourced from [TMC Furniture](#)). Sized to match dimensions of shelving for flush exposure
- Colour – grey or silver finish be selected from standard colour palette (sizable colour samples to be provided).
- 36" wide shelves

- Match approximate shelving heights (52.5", 66"). Include shelving height in response. (Appendix C)
- Sloped slotted box base shelves for all shelving units unless otherwise stated (include catalogue # and photo of shelf).
- Slotted box shelves for all shelving units unless otherwise stated (include catalogue # and photo of shelf).
- Fixed face out display shelves (3" lip) unless otherwise stated (include catalogue # and photo of shelf).
- Shelf riser/filler inserts, to match shelving colour (include catalogue # and photo of filler).
- Book ends with cork bottom, corresponding colour to shelving, (include catalogue # and photo of book end).
- Moveable shelving unit with lockable casters for indicated collections
- All necessary hardware attachments, brackets, trim, top caps, end caps, wall mounts, etc. required for proper installation.
- All shelving to be constructed using a starter and adder concept for assembly.
- All single sided shelving are to be attached to the walls.
- Quantity and location identified as per attached SW Shelving Breakdown PDF (Appendix D)
- Canadian suppliers are preferred.

## Custom End Panel Requirements

The Southwest Community Library requires custom end panels to provide for the merchandising of collections and collection identification signage. The custom end panels must meet the following requirements:

- Designed and constructed as per attached millwork drawings provided to match the custom end panels at our Central location. Attached. (Appendix C)
- Designed and constructed matching custom end panels to fit existing shelving.
- Natural Maple.
- Sized to match dimensions of shelving for flush exposure.
- Quantity and location of custom end panels identified as per attached SW Shelving Breakdown PDF. (Appendix D)

# Appendix A

## References

Organization:	
Address:	Contact Name:
	Phone:
	Email:
Description of work performed:	

Organization:	
Address:	Contact Name:
	Phone:
	Email:
Description of work performed:	

Organization:	
Address:	Contact Name:
	Phone:
	Email:
Description of work performed:	

# Appendix B

## Pricing Submission Form

Shelving and End Panels—Southwest Library

SUBMITTED BY: \_\_\_\_\_ (company name)

I/We the undersigned do hereby offer to supply the requirements, services or perform the scope of work as defined in the Request for Proposal for Kitchener Public Library—Southwest Library, Shelving and End Panels, incorporated herein in full by reference and including any supplementary terms, information and conditions as set out herein.

The total contract price:

- Is in Canadian funds
- Does not include any contingency dollars
- Price includes all expenses, delivery, storage, applicable customs duty, excise tax, freight, insurance disbursements, materials and labour, including overtime, etc.
- Taxes will be extra

COST TO SUPPLY AND INSTALL SHELVING AND END PANELS

(Based on installation being completed during regular business hours)

Sub-total cost \$ \_\_\_\_\_

H.S.T \$ \_\_\_\_\_

Total Cost \$ \_\_\_\_\_

F.O.B. POINT—to be destination, prepaid and not charged to KPL.

Terms of payment are: \_\_\_\_\_

Price is firm for: \$ \_\_\_\_\_

Proposal Submitted by:	
Authorized Signature:	
Date:	
Company Address:	
Phone:	
Email:	

**Appendix C Kitchener Public Library Shelving RFP Excel Sheet**

Unit	SS/DS	Approx. Height	# of Bays	Total # of Shelves	# of Slotted Box Shelves	# of Fixed Face Out Display Shelves	# of Riser/Filler Inserts	Lockable Casters	# of Fixed Magazine Display Shelves	# 9" Book Ends with Cork Bottoms	# 6" Book Ends with Cork Bottoms	# of Sloped Slotted Box Base Shelves	Custom End Panel	Steel End Panel	TMC End Panel	Sub-Total Price
<b>Children's</b>																
															<a href="https://tmc furniture.com/products/end-panels-and-canopy-tops-child/">https://tmc furniture.com/products/end-panels-and-canopy-tops-child/</a>	
A	DS	52.5"	4	32	24	0	0	Yes	0	0	0	8	1	0	1 leaf	
B	DS	52.5"	4	32	24	0	16	Yes	0	0	0	8	1	0	1 leaf	
C	DS	52.5"	4	32	24	0	0	Yes	0	0	0	8	1	0	1 frog	
D	DS	52.5"	4	32	24	0	0	Yes	0	0	0	8	1	0	1 fish	
E	DS	52.5"	4	32	24	0	0	Yes	0	0	0	8	1	0	1 bird	
F	DS	52.5"	4	32	24	0	16	Yes	0	0	0	8	1	0	1 turtle	
G	DS	52.5"	3	24	9	0	9	Yes	9	0	0	6	2	0	0	
H	DS	52.5"	3	24	9	6	9	Yes	3	0	0	6	2	0	0	
<b>TOTAL</b>			<b>30</b>	<b>240</b>	<b>162</b>	<b>6</b>	<b>50</b>		<b>12</b>	<b>0</b>	<b>0</b>	<b>60</b>	<b>10</b>	<b>0</b>	<b>6</b>	
<b>Adult Fiction/Non Fiction and Teen</b>																
I	DS	52.5"	2	16	0	12	0	Yes	0	0	0	4	2	0	0	
J	DS	52.5"	2	16	0	12	0	Yes	0	0	0	4	2	0	0	
K	DS	52.5"	2	16	0	12	0	Yes	0	0	0	4	2	0	0	
L	DS	52.5"	2	16	0	12	0	Yes	0	0	0	4	2	0	0	
M	DS	66"	8	80	60	4	40	No	0	68	12	16	2	0	0	
N	DS	66"	8	72	52	4	0	No	0	72	0	16	2	0	0	
O	DS	66"	8	67	51	0	12	No	0	52	15	16	2	0	0	
P	DS	66"	4	40	30	2	0	No	0	40	0	8	2	0	0	
Q	DS	66"	4	40	30	2	0	No	0	20	20	8	2	0	0	
R	DS	66"	4	32	22	2	32	No	0	20	16	8	2	0	0	
S	SS	66"	4	20	16	0	0	No	0	20	0	4	0	2	0	
T	SS	66"	4	20	16	0	0	No	0	20	0	4	0	2	0	
<b>TOTAL</b>			<b>52</b>	<b>435</b>	<b>277</b>	<b>62</b>	<b>84</b>		<b>0</b>	<b>312</b>	<b>63</b>	<b>96</b>	<b>20</b>	<b>4</b>	<b>0</b>	
<b>Staff Storage</b>																
U	SS	66"	6	30	24	0	0	No	0	30	0	6	0	2	0	
V	SS	66"	2	10	8	0	0	No	0	0	0	2	0	2	0	
W	SS	66"	2	10	8	0	0	No	0	0	0	2	0	2	0	
X	SS	66"	3	15	12	0	0	No	0	0	0	3	0	2	0	
<b>TOTAL</b>			<b>13</b>	<b>65</b>	<b>52</b>	<b>0</b>	<b>0</b>	No	<b>0</b>	<b>30</b>	<b>0</b>	<b>13</b>	<b>0</b>	<b>8</b>	<b>0</b>	
<b>GRAND TOTAL</b>			<b>95</b>	<b>740</b>	<b>491</b>	<b>68</b>	<b>134</b>		<b>12</b>	<b>342</b>	<b>63</b>	<b>169</b>	<b>30</b>	<b>12</b>	<b>6</b>	
<b>Shelf Dividers</b>																
Quantity-222 shelf dividers for slotted shelving, colour to match steel																



# Appendix D

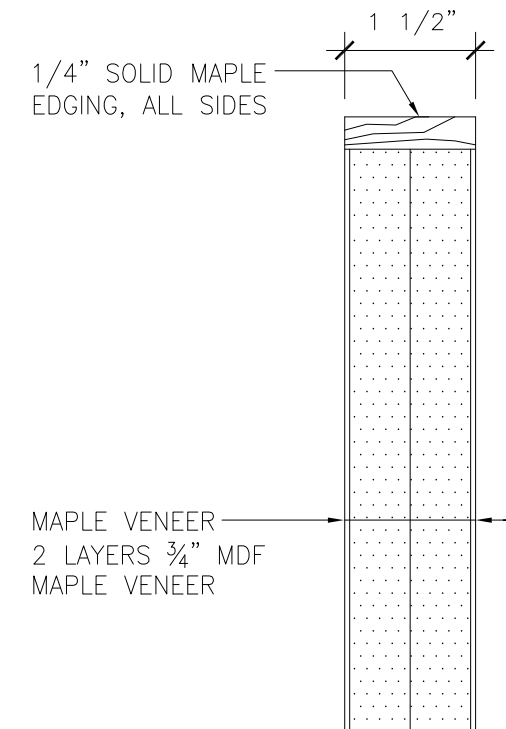
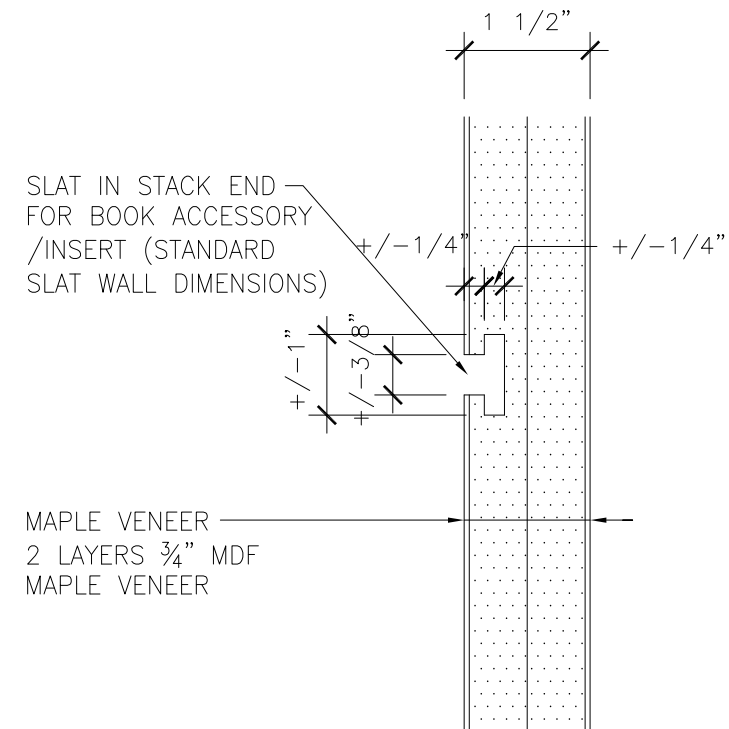
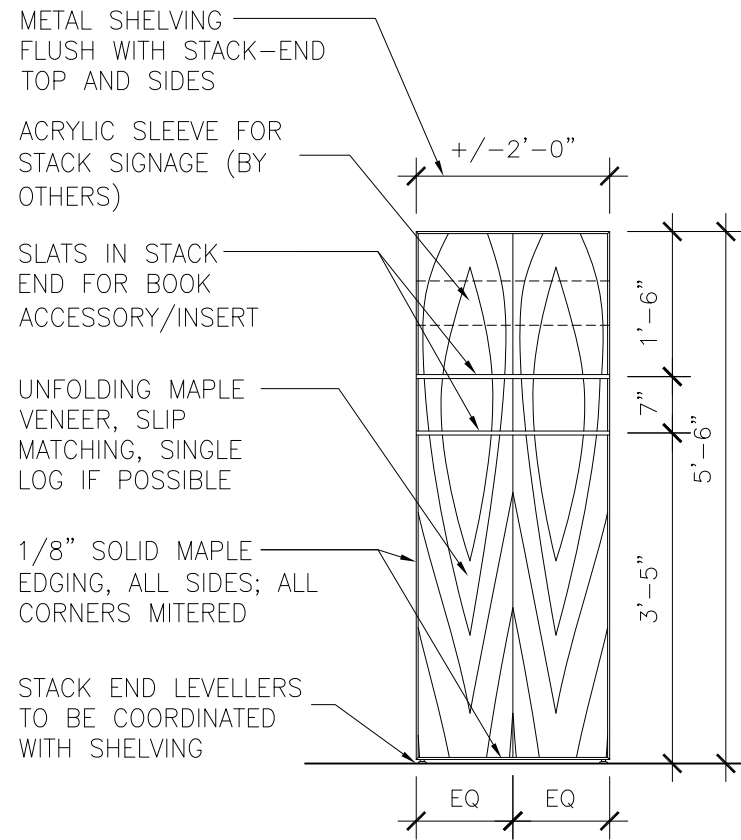
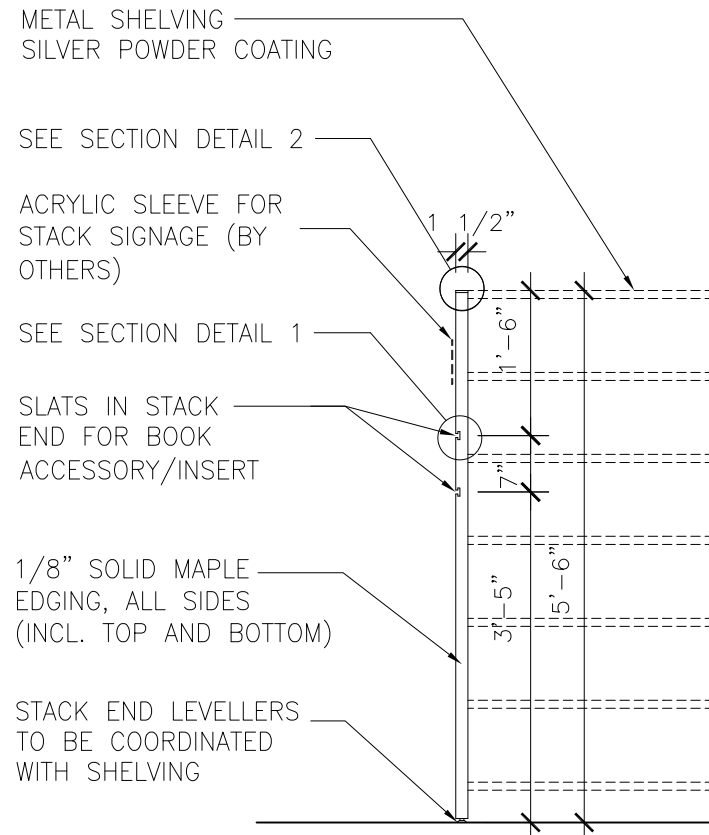

## GENERAL MILLWORK NOTES

- UNLESS OTHERWISE NOTED THE FOLLOWING APPLIES TO ALL MILLWORK:
- ALL REFERENCES TO WOOD VENEER/VENEERED PLYWOOD OR SOLID WOOD TO BE MAPLE, UNLESS OTHERWISE NOTED—CLEAR SATIN FINISH
  - ALL MAPLE VENEER TO BE PLAIN SLICED SELECT WHITE MAPLE. SOLID TRIM TO MATCH
  - PROVIDE SHOP DRAWINGS AND MAPLE FINISH SAMPLE TO ARCHITECT FOR REVIEW AND APPROVALS PRIOR TO FABRICATION

## SIDE ELEVATION:

SCALE: 1/2"=1'

## FRONT ELEVATION

SCALE: 1/2"=1'

## SECTION DETAIL 1

## SECTION DETAIL 2

PROJECT:

**KPL FURNITURE**  
KITCHENER, ONTARIO

DRAWING TITLE:

**66" HIGH STACK END  
MILLWORK**

# Appendix D

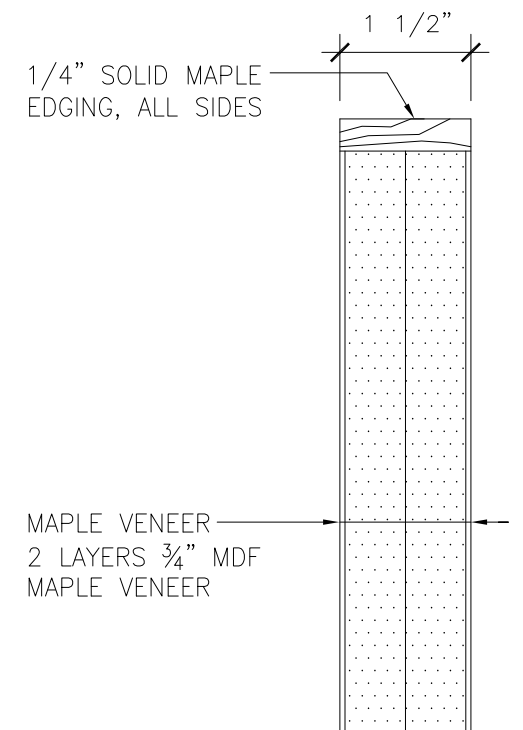
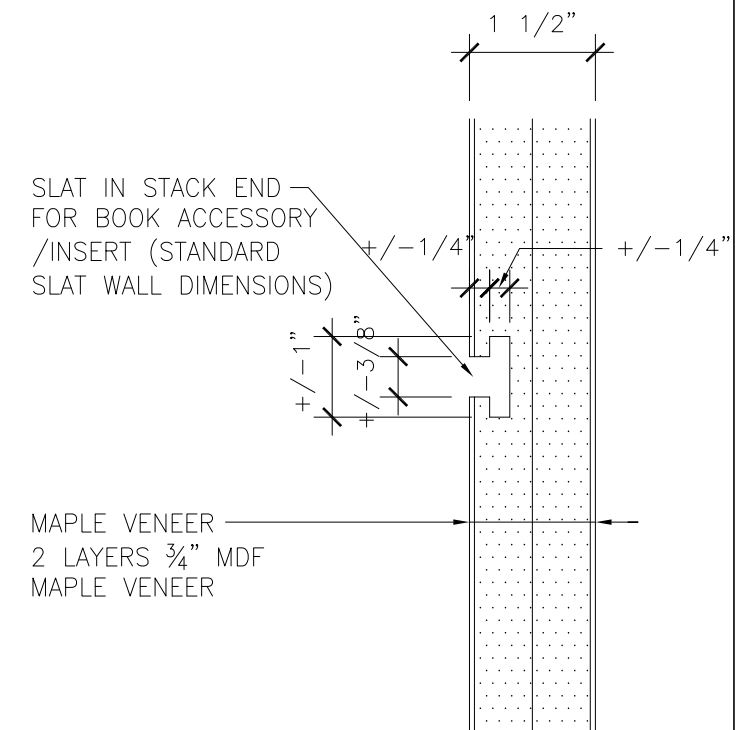
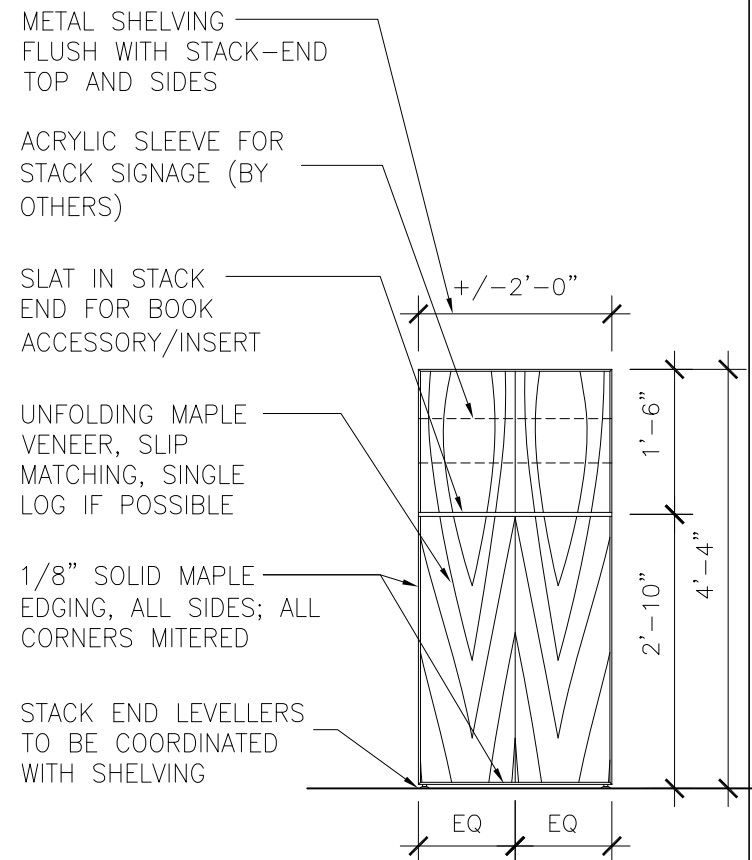
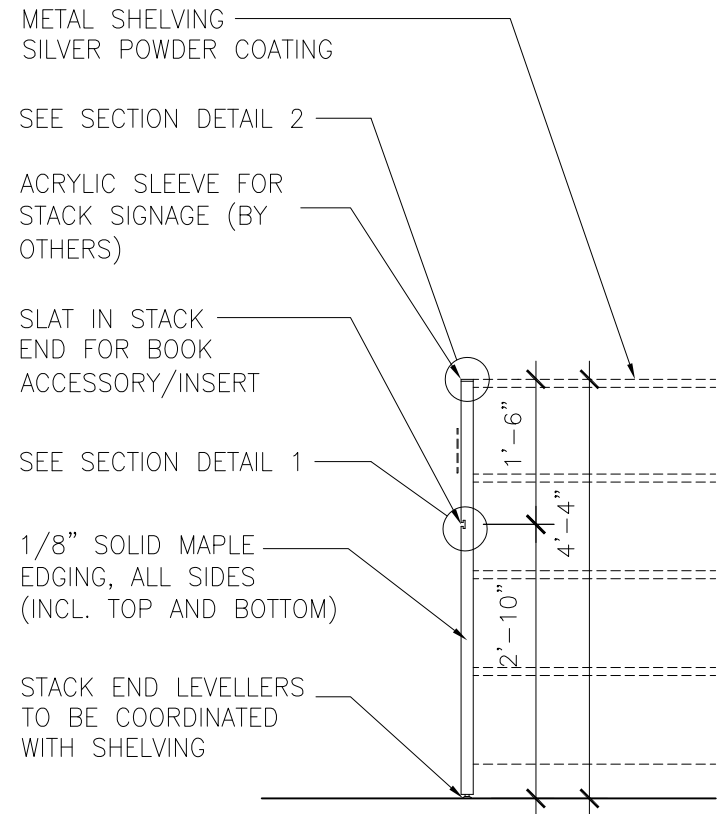

**GENERAL MILLWORK NOTES**

- UNLESS OTHERWISE NOTED THE FOLLOWING APPLIES TO ALL MILLWORK:
- ALL REFERENCES TO WOOD VENEER/VENEERED PLYWOOD OR SOLID WOOD TO BE MAPLE, UNLESS OTHERWISE NOTED—CLEAR SATIN FINISH
  - ALL MAPLE VENEER TO BE PLAIN SLICED SELECT WHITE MAPLE. SOLID TRIM TO MATCH
  - PROVIDE SHOP DRAWINGS AND MAPLE FINISH SAMPLE TO ARCHITECT FOR REVIEW AND APPROVALS PRIOR TO FABRICATION

**SIDE ELEVATION:**

SCALE: 1/2"=1'

**FRONT ELEVATION**

SCALE: 1/2"=1'

**SECTION DETAIL 1**

**SECTION DETAIL 2**

PROJECT:

**KPL FURNITURE**  
KITCHENER, ONTARIO

DRAWING TITLE:

**52" HIGH STACK END  
MILLWORK**